



RANGE / CAPACITY

-25°C / -15°C

VASCHEFFE GELATO	60	VASCHEFFE GELATO	42	POZZETTI GELATO	40
Vaschette-Pans 165x360xH120(mm)		Vaschette-Pans 165x360xH180(mm)		step 280mm Ø200xH250(mm)	

CARATTERISTICHE

- Costruzione in acciaio inox Aisi 304 con finitura esterna Scotch Brite
- Struttura monococca con bocca di carico maggiorata in altezza e grande volume di carico
- Fianchi vano motore schiumati per una migliore robustezza ed insonorizzazione
- Fianchi con isolamento 85 mm in poliuretano espanso ad alta densità (circa 42 kg/m3) privo di HCFC
- Interno raggiato per facilitare le operazioni di pulizia
- Porte auto-chiudenti e reversibili (con kit)
- Cornice porta con resistenza facilmente sostituibile
- Guarnizione porta magnetica, sostituibile senza attrezzature
- Cerniere porta adatte al montaggio su zoccolo in muratura
- Piedi in acciaio inox AISI304 18/10 regolabili in altezza
- Supporti portaguide a doppia punzonatura, passo 34mm e 59mm
- Dotazione standard: 5 vassoi estraibili su coppia guide a C antiribalta
- Possibilità di inserire fino a 41 ripiani con passo 34mm
- Sbrinamento a gas caldo
- Sistema refrigerazione ventilato
- Livello rumorosità dB(A) <70
- Gruppo refrigerante a monoblocco

FEATURES

- AISI 304 stainless steel construction with external Scotch brite finish
- Monocoque structure with increased loading volume
- Foamed engine compartment sides for improved strength and soundproofing
- Sides with 85 mm insulation in high density expanded polyurethane (about 42 kg / m3) without HCFC
- Rounded edges interior to facilitate cleaning
- Self-closing and reversible doors (with kit)
- Door frame with removable heating element
- Magnetic door gasket, replaceable without equipment
- Door hinges suitable for installation on plinth
- Feet in stainless steel adjustable in height
- Double pitch trayholders, every 34 and 59mm
- Standard equipment: 5 extractable trays on a pair of anti-tipfor C guides
- Possibility to insert up to 41 shelves with 34mm pitch
- Hot gas defrost
- Ventilated refrigeration system
- Noise level dB(A) <70
- Monobloc refrigeration unit

OPTIONAL / OPTIONAL

- Kit ruote, 2 con freno
- Condensazione ad acqua
- Guide addizionali
- Wheel kit, 2 with brake
- Water cooling
- Additional guides

CONTROLLO & IOT / CONTROL & IOT

Capacitive Full touch 4.3 "display
 Internet ready/cloud/diagnosis
 and remote control / IOT e
 Industry 4.0 ready / Integrated
 network card with Ethernet
 output included (WIFI optional)

Display Full touch capacitivo da
 4.3 " / Connessione Internet
 nativa / cloud / diagnostica e
 controllo remoti / IOT e Industry
 4.0 ready / Scheda di rete
 integrata con uscita Ethernet
 inclusa (WIFI opzionale);

CARATTERISTICHE / FEATURES

Alimentazione Elettrica / Power supply	230V/1N/50HZ
Codice Prodotto / Code number	CVS GEL
Dimensioni / Dimensions (LxPxX) (WxDxH)	790 x 915 (1645) x 2110 mm
Classe climatica - VOLume netto / Climatic class - Net volume	5L1 - 607,0 lt
Classe energetica / Energetic class	D
Consumo energia / Energy consumption (ISO22041)[kW24h]	6.96
Fluido refrigerante / Refrigeration Fluid	150g - R290 (GWP 3)
Potenza refrigerante / Cooling power (-10/+45 EN12900)	1379 W
Corrente / Current	3,3 A
Coppie Guide - Teglie / Pairs of slide - Trays	5 - 600 x 730 mm
Peso netto - lordo / net - gross Weight	171 / 206 Kg
Dati spedizione / Shipment data	845 x 980 x 2200 mm - 206 Kg

our technology,
your taste

DIMENSIONI / DIMENSIONS

VISTA FRONTALE / FRONT VIEW

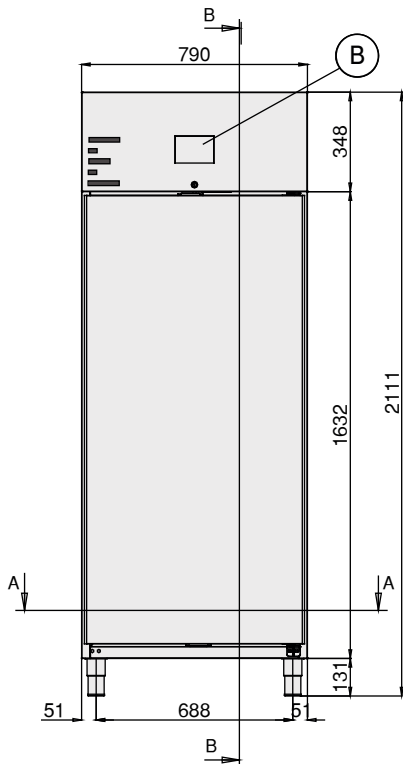

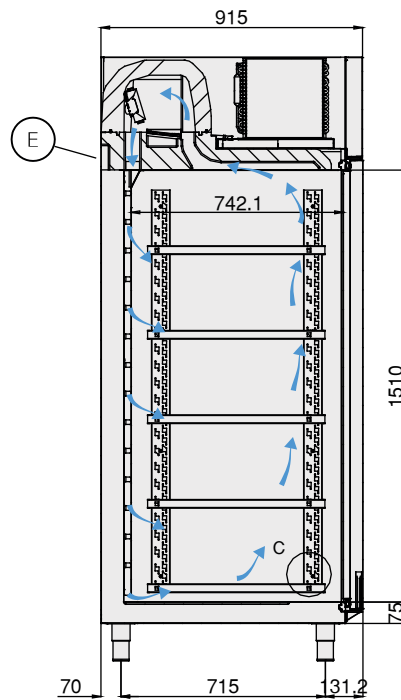

VISTA LATERALE / LATERAL VIEW





-25°C/-15°C

Sez. B-B

-  Electrical cable supply
Cavo alimentazione elettrica
-  Command interface
Pannello comandi
-  Round air system

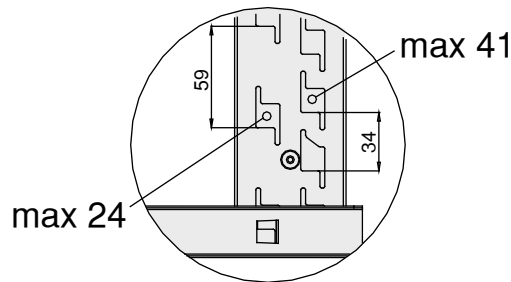
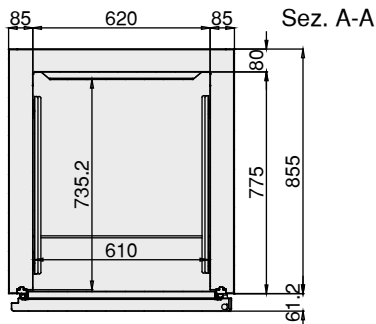
VISTA SUPERIORE / TOP VIEW



-  Cavo Alimentazione
Supply cable
n° x mm² (2+1)x1,5mm²

QUADRO COMANDI / CONTROL PANEL

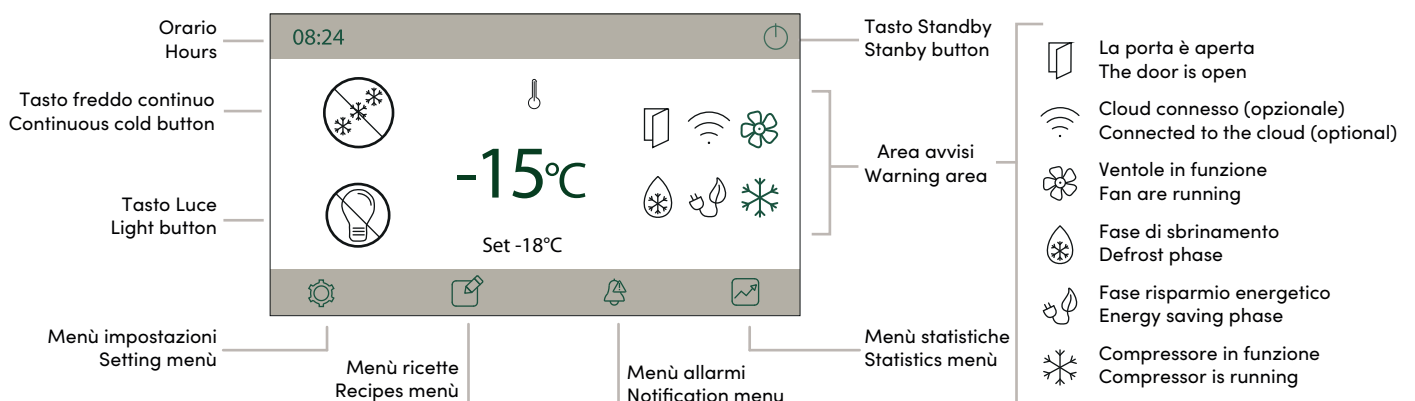

our technology,
 your taste

CAPACITA' / CAPACITY

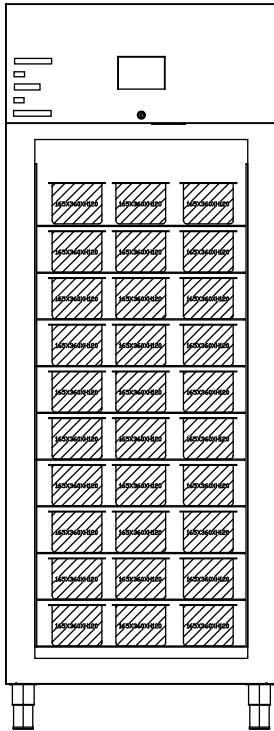

Vaschette - Pans
 165mm x 360mm x H120mm

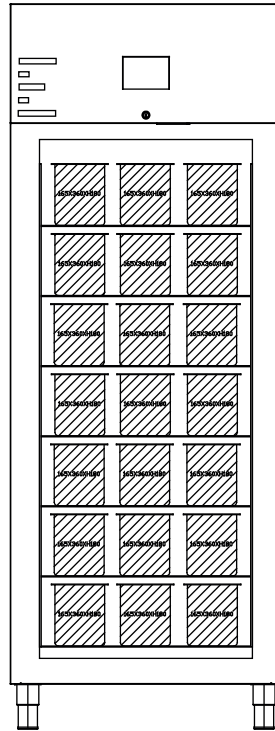

Vaschette - Pans
 165mm x 360mm x H180mm

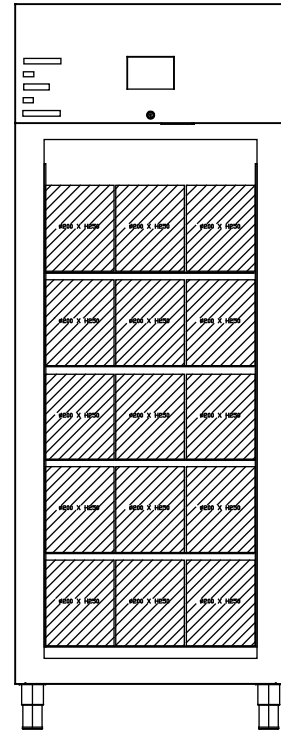

Pozzetti - Wells
 Ø200 mm x H250mm

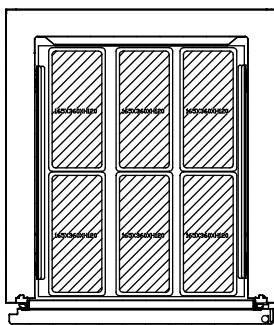

TEGLIA 600X730

60 pcs.

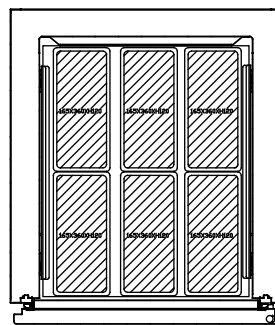

TEGLIA 600X730

42 pcs.

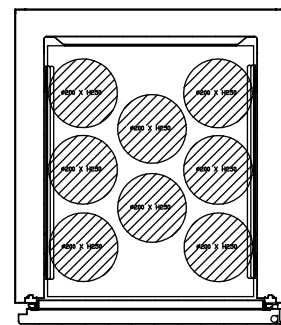

TEGLIA 600X730

40 pcs.