



RANGE / CAPACITY

-25°C / -15°C

GRIGLIE **41** GRIGLIE **24**

Grids step 34 mm
600 x 730 (mm)

Grids step 59 mm
600 x 730 (mm)

CARATTERISTICHE

- Costruzione in acciaio inox Aisi 304 con finitura esterna Scotch Brite
- Struttura monococca con bocca di carico maggiorata in altezza e grande volume di carico
- Fianchi vano motore schiumati per una migliore robustezza ed insonorizzazione
- Fianchi con isolamento 85 mm in poliuretano espanso ad alta densità (circa 42 kg/m³) privo di HCFC
- Interno raggiato per facilitare le operazioni di pulizia
- Porte auto-chiudenti e reversibili (con kit)
- Cornice porta con resistenza facilmente sostituibile
- Guarnizione porta magnetica, sostituibile senza attrezzature
- Cerniere porta adatte al montaggio su zoccolo in muratura
- Piedi in acciaio inox AISI304 18/10 regolabili in altezza
- Supporti portaguide a doppia punzonatura, passo 34mm e 59mm
- Dotazione standard: 10 coppie guide ad "L"
- Possibilità di inserire fino a 41 ripiani con passo 34mm
- Sbrinamento a gas caldo
- Sistema refrigerazione ventilato
- Livello rumorosità dB(A) <70
- Gruppo refrigerante a monoblocco

FEATURES

- AISI 304 stainless steel construction with external Scotch brite finish
- Monocoque structure with increased loading volume
- Foamed engine compartment sides for improved strength and soundproofing
- Sides with 85 mm insulation in high density expanded polyurethane (about 42 kg / m³) without HCFC
- Rounded edges interior to facilitate cleaning
- Self-closing and reversible doors (with kit)
- Door frame with removable heating element
- Magnetic door gasket, replaceable without equipment
- Door hinges suitable for installation on plinth
- Feet in stainless steel adjustable in height
- Double pitch trayholders, every 34 and 59mm
- Standard equipment: 10 pairs of "L" guides
- Possibility to insert up to 41 shelves with 34mm pitch
- Hot gas defrost
- Ventilated refrigeration system
- Noise level dB(A) <70
- Monobloc refrigeration unit

OPTIONAL / OPTIONAL

- Kit ruote, 2 con freno
- Guide addizionali
- Wheel kit, 2 with brake
- Additional guides

CONTROLLO & IOT / CONTROL & IOT

Capacitive Full touch 4.3 "display
Internet ready/cloud/diagnosis
and remote control / IOT e
Industry 4.0 ready / Integrated
network card with Ethernet
output included (WIFI optional)

Display Full touch capacitivo da
4.3 " / Connessione Internet
nativa / cloud / diagnostica e
controllo remoti / IOT e Industry
4.0 ready / Scheda di rete
integrata con uscita Ethernet
inclusa (WIFI opzionale);

CARATTERISTICHE / FEATURES

Alimentazione Elettrica / Power supply	230V/1N/50HZ
Codice Prodotto / Code number	CVS BT
Dimensioni / Dimensions (LxPxX) (WxDxH)	790 x 915 (1645) x 2110 mm
Classe climatica - Volume netto / Climatic class - Net Volume	5L1 - 607,0 lt
Classe energetica / Energetic class	D
Consumo energia / Energy consumption (ISO22041)[kW24h]	6,96
Fluido refrigerante / Refrigeration Fluid	150 g - R290 (GWP 3)
Potenza refrigerante / Cooling power (-10/+45 EN12900)	1379 W
Corrente / Current	3.3 A
Coppie Guide / Pairs of slide	10
Peso netto - lordo / net - gross Weight	143 / 172 Kg
Dati spedizione / Shipment data	845 x 980 x 2200 mm - 172 Kg

our technology,
your taste

DIMENSIONI / DIMENSIONS

VISTA FRONTALE / FRONT VIEW

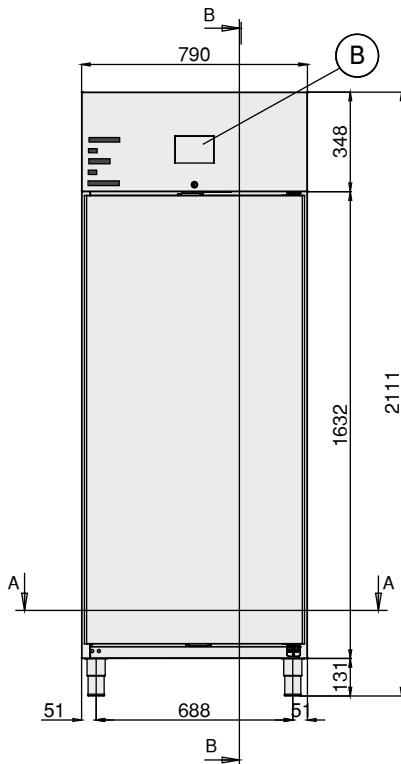

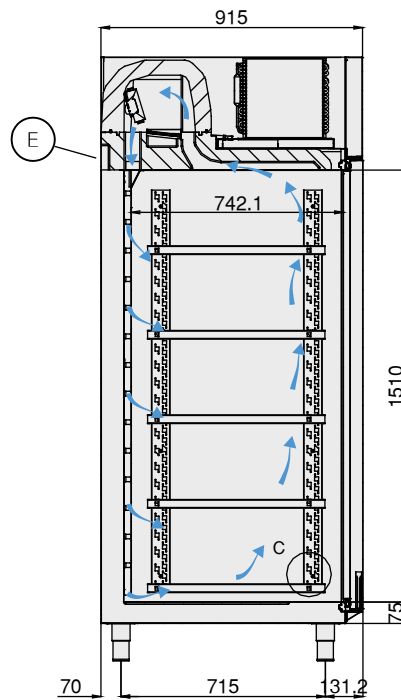

VISTA LATERALE / LATERAL VIEW





-25°C/-15°C

Sez. B-B

-  Electrical cable supply
Cavo alimentazione elettrica
-  Command interface
Pannello comandi
-  Round air system

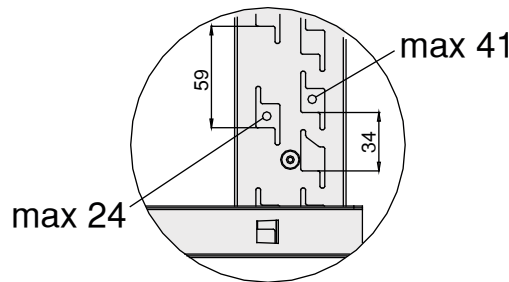
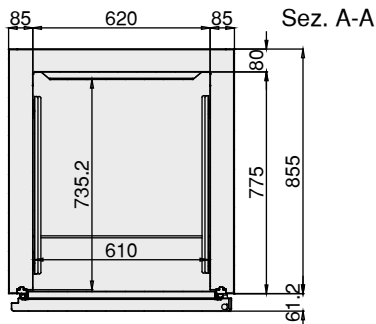
VISTA SUPERIORE / TOP VIEW



-  Cavo Alimentazione
Supply cable
n° x mm² (2+1)x1,5mm²

QUADRO COMANDI / CONTROL PANEL

