

Tutti i modelli / All models:

CGS TNN - CGS BT - CVes GEL

CVS TNN - CVS BT - CVS GEL

CVL TNN - CVL BT - CVL GEL - CCS-CSS GEL

## CGSTNN

### 230V 1N 50hz

### Refrigerated Cabinet



#### RANGE / CAPACITY

# -2°C / +8°C

GRIGLIE  
GRIDS

## 24

Griglie/Grids GN2/1  
650 x 530 mm  
Passo/step 55 mm

#### CARATTERISTICHE

- Costruzione in acciaio inox Aisi con finitura esterna Scotch Brite
- Fianchi con isolamento 83 mm in poliuretano espanso ad alta densità (circa 42 kg/m<sup>3</sup>) privo di HCFC
- Interno raggiato per facilitare le operazioni di pulizia
- Porte auto-chiudenti
- Supporti guide stampati
- Cerniere porta adatte al montaggio su zoccolo in muratura
- Piedi in acciaio inox AISI regolabili in altezza
- Dotazione standard: 3 griglie plastificate GN 2/1
- Sbrinamento automatico
- Sistema refrigerazione ventilato
- Livello rumorosità dB(A) <70
- Gruppo refrigerante a monoblocco
- Passo griglie 55 mm

#### FEATURES

- AISI stainless steel construction with external Scotch brite finish
- Sides with 83 mm insulation in high density expanded polyurethane (about 42 kg / m<sup>3</sup>) without HCFC
- Rouded edges interior to facilitate cleaning
- Self-closing doors
- Cantilever guide supports
- Door hinges suitable for installation on plinth
- Feet in stainless steel adjustable in height
- Standard equipment: 3 GN 2/1 plastic coated grids
- Automatic defrost
- Ventilated refrigeration system
- Noise level dB(A) <70
- Monobloc refrigeration unit
- grid distance 55 mm

#### OPZIONI

- Kit ruote, 2 con freno

#### OPTIONAL

- Wheel kit, 2 with brake

#### CARATTERISTICHE / FEATURES

Alimentazione Elettrica / Power supply	230V/1N/50HZ
Codice Prodotto / Code number	<b>CGS TNN</b>
Dimensioni / Dimensions (LxPxX) (WxDxH)	700 x 830 (1490) x 2080 mm
Classe climatica / Climatic class	5M1
Classe energetica / Energetic class	B
Consumo energia / Energy consumption (ISO22041)[kW24h]	0.97
Fluido refrigerante / Refrigeration Fluid	R290 (GWP 3)
Potenza refrigerante / Cooling power	294 W
Max Potenza - Corrente / Electric Power - Current Max	295 W - 1,1 A
Peso netto - lordo / net - gross Weight	117 / 130 Kg
Dati spedizione / Shipment data	740 x 890 x 2200 mm - 130 Kg

Tutti i modelli / All models:

CGS TNN - CGS BT - CVes GEL

CVS TNN - CVS BT - CVS GEL

CVL TNN - CVL BT - CVL GEL - CCS-CSS GEL

## CGSTNN

### 230V 1N 50hz

Refrigerated Cabinet

our technology,  
your taste

#### DIMENSIONI / DIMENSIONS

### -2°C/+8°C

VISTA FRONTALE / FRONT VIEW

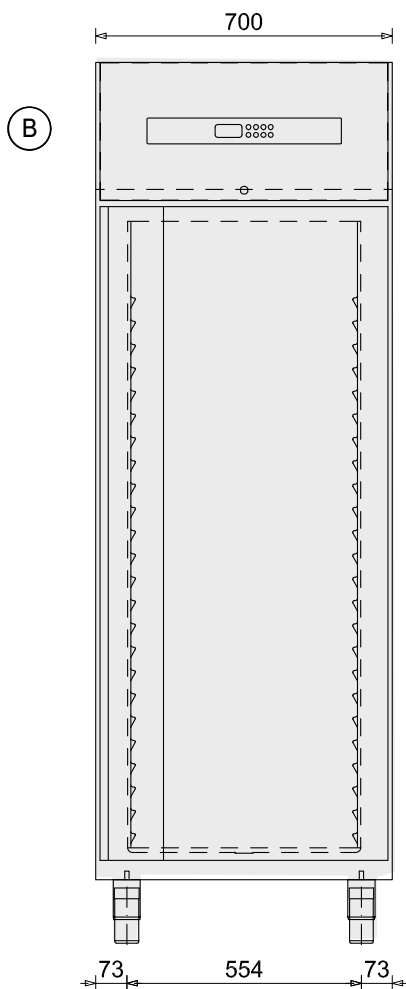

VISTA LATERALE / LATERAL VIEW

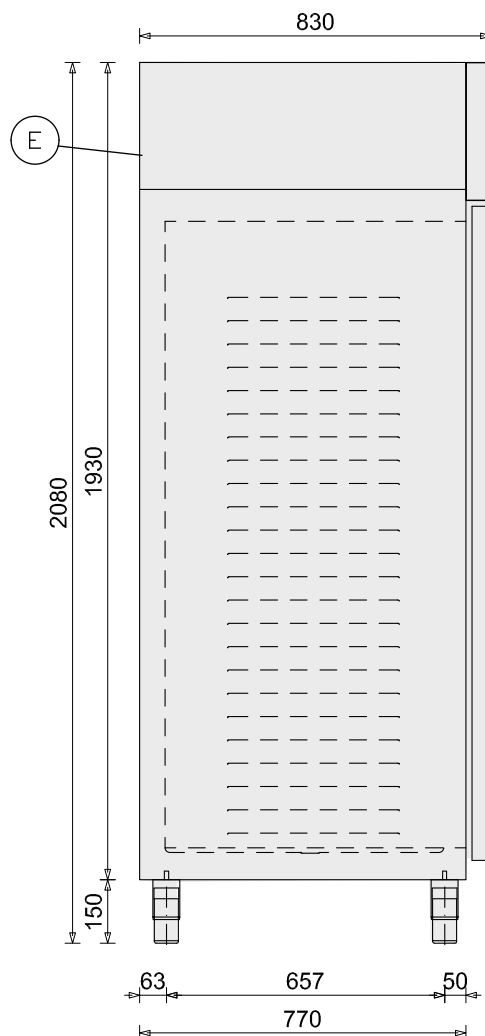

(E) Electrical cable supply  
Cavo alimentazione elettrica

(B) Command interface  
Pannello comandi

VISTA SUPERIORE / TOP VIEW

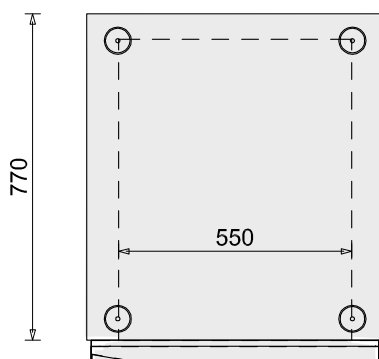

(i) Cavo Alimentazione  
Supply cable  
n° x mm<sup>2</sup> (2+1)x1,5mm<sup>2</sup>